

REALE | F

SERIES



S-EGASEATING ©
The leading Turkish brand of quality Auditorium, Theatre and Cinema Seating

www.egaseating.com

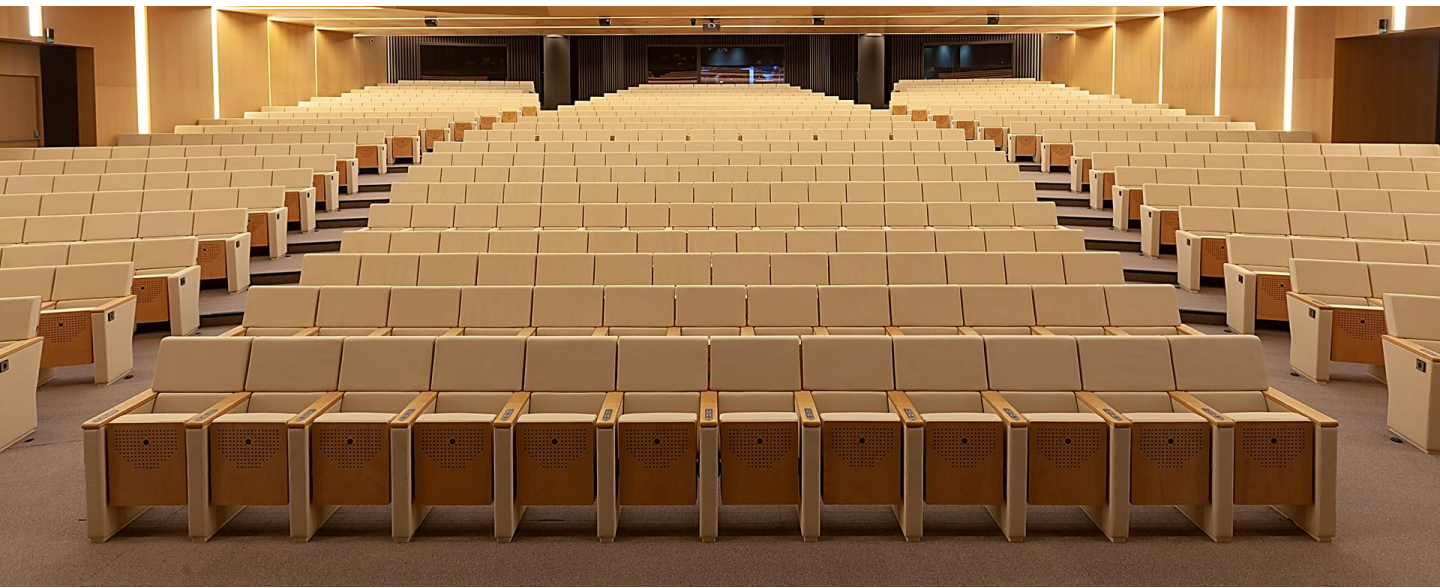

REALE series auditorium seats are the most important version in the collection, where the classic elegance of the backrest and the soft line of the seat combine all the features of functionality and ergonomics, expressing them at their best.

Its compact structure allows for ease of access and egress and the extensive backrest options ensure maximum comfort and function.

Designed to be comfortable and maintenance-free throughout its lifetime, this seat provides the highest levels of comfort.

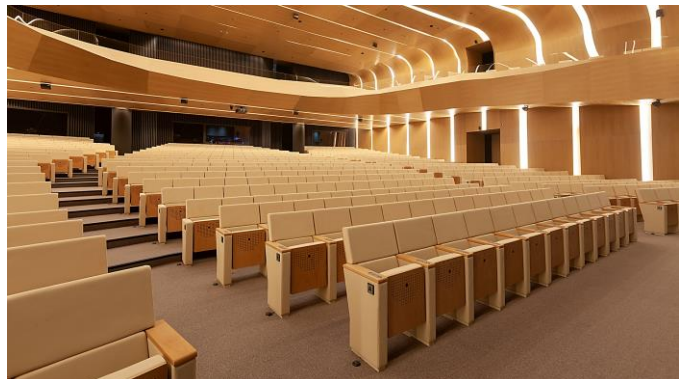



REALE series are manufactured under the needs of conference and theater halls and in ergonomic designs targeting comfort that fits the audience perfectly.

The series is in line with the needs of the investor and the audience;

It is enriched with

- *side panels,*
- *fabric or leather upholstery,*
- *backrest and seat unit wooden covers.*



OPTION FEATURES

REALE | F-BSF

- (F) The lateral feet are fully upholstered with padded cover.
- (BSF) Both backrest and seat padding are fully upholstered with padded cover.



REALE | FW-BSF

- (FW) The lateral feet fully upholstered, finished with solid wooden armrest unit.
- (BSF) Both backrest and seat padding are fully upholstered with padded cover.



REALE | FW-BW

- (FW) The lateral feet fully upholstered, finished with solid wooden armrest unit.
- (BW) The backrest padding is supported by a varnished beech plywood backboard.



REALE | FW-BSW

- (FW) The lateral feet fully upholstered, finished with solid wooden armrest unit.
- (BSW) Both backrest and seat padding are supported by a varnished beech plywood backboard.



DIMENSIONS (mm)

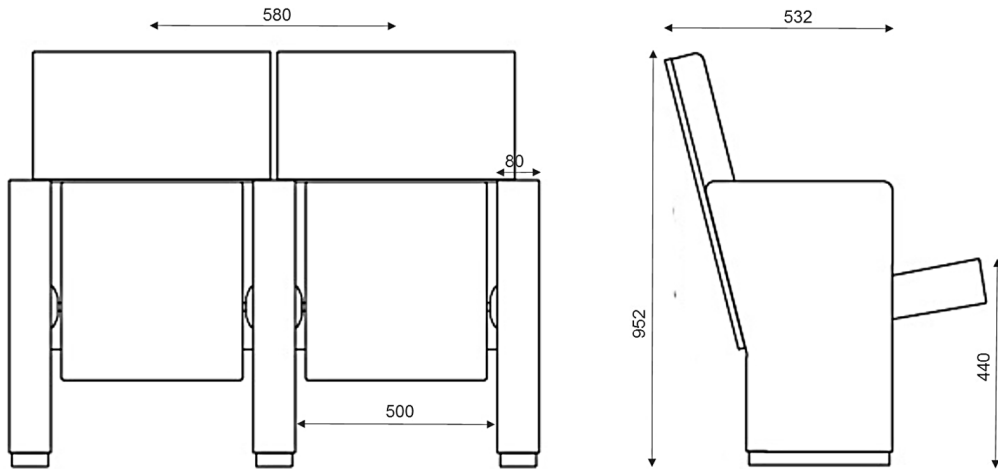

CHARACTERISTIC FEATURES

Dimensions

- Center-to-center dimension is 58 cm.
- The nominal space for the user is 50 cm.

Seat and Backrest units

- All paddings are produced with cold-molded CMHR polyurethane foam technology,
- Both backrest and seat padding has a carefully crafted ergonomic design, density of 50-60 kg/m³.
- The seat padding is a single block of molded polyurethane foam that incorporates an internal metal frame structure, plus supported by an internal flat springs structure to provide sitting comfort long time.
- The backrest is made of 18 mm thick beech plywood, incorporating two fully upholstered, open-cell polyurethane foam cushions which, due to their shape and composition, offer great back and lumbar support.
- Upholstered with a padded cover, removable utilizing a zipper.
- The tip-up seat folds automatically with an inside weight balance system. Silent and maintenance-free.

Optional

- Controlled Slow Rising System** by means of silent, controlled slow movement with no bumps.
- The seat folds up automatically with controlled slow movement by a pneumatic piston mechanism located at the side panel. Totally silent and maintenance-free.

Armrests

- Fixed and shared armrest box in ergonomic design.
- Fully upholstered with a padded cover.
- Optional, wooden armrest made of 20mm thick varnished solid wood.

Fabric Specification

- Abrasion rate Martindale: 60.000 cycles, Weight: 460 gr/m², 100% polyester.
- Non-flammability standard: ECE-R118, FMVSS 302, EN 1021-1/2 standards
- The back surface of the fabric is laminated with a 4 mm thick sponge that is laminated with flame lamination (glueless) technique.

Structure

- The lateral feet are single block units made of unified double 40 mm thick MDF boards designed and produced to provide durability and long life.
- The lateral legs are fully upholstered with padded covers.
- The lateral legs are joined to a steel base and fixed to the floor using metric screws or other suitable types of anchorage for each type of surface.
- The backrest unit is fixed to the lateral legs with a concealed metal slide insertion system that provided strong durability.
- The system is very resistant and ensures the perfect alignment of the backrests when forming a row.
- The metal parts are painted with electrostatic powder paint. Coat thickness 80 microns \pm 10.

Options

- Backrest wooden cover-Beech plywood.
- Seat back wooden cover-Beech plywood perforated.
- Seat, row numbering and logo embroidery.
- Variety of foam density.
- Variety of fabric with abrasion, fading and non-flammability characteristics.
- Variety of high quality faux and genuine leather.